

**VESTIL MANUFACTURING CORP.**  
2999 N. Wayne St., Angola, IN 46703  
Ph: 260-665-7586 · Fax: 260-665-1339  
E-mail: sales@vestil.com • Website: www.vestil.com

# OWNER'S MANUAL

## MODELS EM1-200 & -500, EHTT, EHTT-L

Serial number \_\_\_\_\_

Installation Instructions .....	2	Electrical & Hydraulic Diagrams & BOM .....	10-12
Operation Instructions .....	3	Power Unit's Operation .....	13
Routine Maintenance & Safety Checks .....	4	Troubleshooting .....	14
Exploded Structural Parts Drawing & BOM .....	5-8	Safety Label Identification .....	15-16
Motor and Transformer Connections .....	9	Warranty .....	17

### WARNINGS AND SAFETY INSTRUCTIONS

Ensure that all employees understand and follow the following.

- Read and understand the owner's manual before using or servicing the tilting table.
- The load must be removed, and the platform either positively and adequately supported or fully tilted, before any work is performed on the tilter.
- Ensure that all safety and warning labels stay in place and are legible.
- Do not use the tilting table if any damage or unusual noise is observed.
- Always watch the platform and the container carefully when the tilter is in operation.
- Do not perform any modifications to the tilting table without the manufacturer's approval. Failure to receive authorization for changes to the equipment could void the warranty.
- Maintenance and repairs are to be done only by personnel qualified to perform the required work.
- Do not use brake fluid or jack oils in the hydraulic system. If oil is needed, use an anti-wear hydraulic oil with a viscosity grade of 150 SUS at 100°F, (ISO 32 cSt @ 40°C), or Dexron transmission fluid.
- Contact the manufacturer for any needed MSDS information.

### WHEN ORDERING

#### REPLACEMENT PARTS:

We take pride in using quality parts on the equipment we manufacture. We are not responsible for equipment problems resulting from the use of unapproved replacement parts.

To order replacement or spare parts for this equipment, contact the factory.

In any communication with the factory please be prepared to provide the machine's serial number, which is indicated on the machine dataplate.

### RECEIVING INSTRUCTIONS

Every unit is thoroughly tested and inspected prior to shipment. However, it is possible that the unit could incur damage during transit.

Inspect the unit closely when it arrives. *If you see evidence of damage or rough handling to either the packaging or to the product when it is being unloaded, **immediately** make a note of it on the Bill Of Lading!*

It is important that you remove the product's packaging upon its arrival to ensure that there is no concealed damage or to enable a timely claim with the carrier for freight damage.

Also verify that the product and its specifications are as ordered.

EM1-200

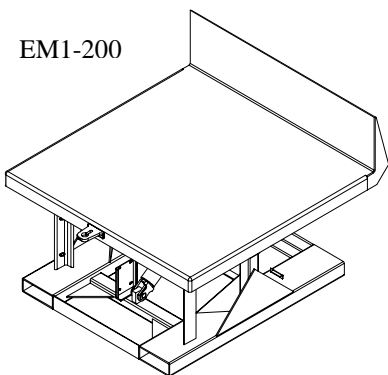

EM1-500

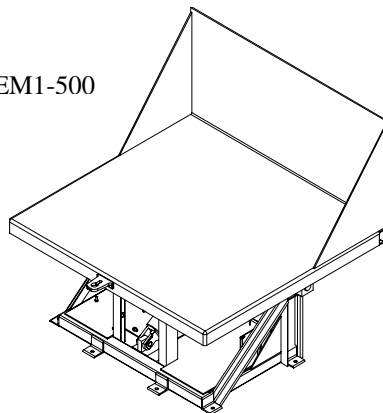

EHTT

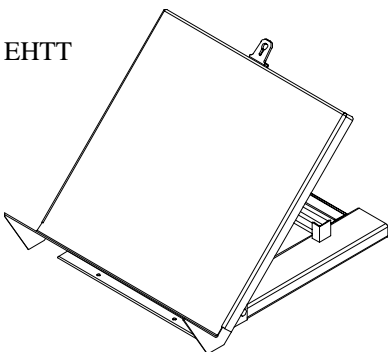

EHTT-L

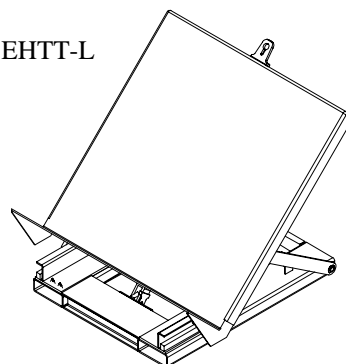

## INSTALLATION INSTRUCTIONS – EM1-200 & -500, EHTT, EHTT-L

*Review this entire page before installing the tilting table.*

*Consult the factory in the event there are any questions or problems at the time of installation, or for information regarding optional features not covered by the owner's manual.*

*The tilting table must be removed from the shipping wood and securely anchored to the floor before use! The EM1-500 platform must be tilted to the 90° position, and supported if necessary, before removing the shipping wood.*

- Modifications or additions to the tilting table without prior manufacturer's authorization may void the unit's warranty. The addition of ancillary equipment to the platform may necessitate that its load capacity be reduced.
- The installation must be made so that it complies with all the regulations applicable to the machine and its location. The end-user must verify that the supplied equipment is installed so it will be suited to the environment in which it will be used.
- Installation must be performed by suitably trained personnel with access to the appropriate equipment. The electrical aspects of the installation should be performed by an electrician.

-----  
 For a typical installation of a standard tilting table you will need the following:

1. A fork truck or hoisting means to unload the tilting table from the freight truck and set it into place.
2. A smooth, level, and adequately strong concrete surface on which to mount and operate the tilting table.
3. Concrete anchors, a masonry drill, a masonry bit, hand tools, grout, and steel shims. Consult the building's architect or facility engineer to determine the best size and type of hardware with which to anchor the machine to the floor.
- Units designed to be portable do not need to be anchored to the floor.
4. A power supply circuit and electrical disconnect matching the motor voltage and current requirements. Refer to the machine's dataplate, to the labels on the control enclosure, and to the electrical section in this manual for more information. The end-user is responsible for supplying the branch circuit's required ground fault and short-circuit protection. (Motor overload protection is provided by a thermostat built into the motor.)

-----  
 To install a standard non-portable tilting table:

1. Remove the shipping boards from underneath the tilter's frame.  
*Caution:* On EM1-500's, tilt the platform down fully (the cylinder will be extended) before removing the boards. Otherwise, the unit could be top-heavy and tip over unexpectedly.
2. Move the tilter into place with a fork truck having at least a 2,000 lb capacity.
3. Temporarily connect the power supply to the pigtail cord supplied with the tilting table, and tilt the platform to its maximum angle so that the control enclosure is accessible.
  - If the platform must be tilted without first having the proper power supply connected, support under the backstop side of the platform by either attaching rigging from a crane or hoist, or inserting a lift truck's forks under the platform. Carefully unpin one end of the cylinder(s) and allow the platform to tilt to its maximum angle. Once the power supply is connected, press the LOWER pushbutton to allow the cylinders to retract. (Single-acting cylinders must be manually compressed in order to retract.) Finally, reinstall the cylinder pin and its hardware.
4. Anchor the frame to the floor through each anchoring bracket located at the frame's perimeter using appropriate concrete anchors.
5. Make permanent connection to the power supply, using an appropriate wiring method.
6. Operate the tilting table through several full raise and lower cycles. Verify that the limit switch(es) functions properly.
7. Check the hydraulic oil level. It should be within 1" of the reservoir's fill hole with the cylinders retracted. If oil is needed, use an anti-wear hydraulic oil with a viscosity grade of 150 SUS at 100°F (ISO 32 at 40°C) or a non-synthetic automatic transmission fluid.
8. Clean up any debris or spilled oil, and verify that all of the warning and safety labels are in good condition.

## OPERATION INSTRUCTIONS – EM1-200 & -500, EHTT, EHTT-L

- Consult ANSI MH29.2 - 2000, Safety Requirements for Industrial Tilters, Section 12, for the owner's / user's responsibilities regarding the operation, care, and maintenance of this machine.
- Ensure that all employees involved in the operation of this machine understand and follow these instructions!

The standard tilt table models are suitable for use indoors in most industrial locations and many commercial locations. They are intended to be used to tilt stable, non-hazardous loads and containers with rigid sides having a size or footprint appropriate for the tilter's platform and backstop dimensions.

### Loading:

The load rating, in pounds, is shown on the machine dataplate located on the front side (opposite the backstop) of the platform. It indicates the net capacity of the machine with a static load that is centered and evenly distributed on the platform, and having a vertical center of gravity not more than 20" above the platform surface and a horizontal center of gravity not more than 20" from the backstop.

For applications involving dynamic loads, such as for use with conveyor systems which create side or end edge loading of the platform, consult the factory.

Do not exceed a rate of one foot per second when moving loads onto or across the platform.

Always center the load *against* the backstop of the platform to prevent sudden load shifting when the platform is tilted.

*Note:* The addition of any ancillary equipment to the platform by third parties must be taken into account when determining the maximum working load to be placed on the platform.

*Warning:* Do not exceed the tilting table's load ratings. Injury to personnel or permanent damage to the structure could result from exceeding the listed capacity.

### Operation:

*Warning:* Keep all personnel clear of the machine when it is in operation. Be certain no part of any person or object is under any part of the platform before lowering the unit.

*Caution:* Always carefully watch the container and any load in it when it is in operation.

The tilting table is furnished with either a constant-pressure (dead-man style) pushbutton (standard), or a twin foot switch (optional) control.

*Note:* The tilter is "raising" when the platform to which the cylinder is attached is moving to the level position. Therefore, on standard EM1-200 and EM1-500 units, the cylinder(s) will *extend* when the "UP" control is pressed. On standard EHTT and EHTT-L units, the cylinder(s) will *retract* when the "UP" control is pressed.

For all models:

Pressing the "UP" pushbutton or foot switch will turn on the power unit to raise the platform. The platform will raise only while the control is pressed. Upon releasing the control, the platform will stop and hold its position.

For the EM1-200:

Pressing the "DOWN" pushbutton or foot switch will energize the lowering valve to allow the platform to descend by gravity (the motor does not run). Again, releasing the control will stop the platform movement, and the unit will hold its position.

For the EM1-500, EHTT, and EHTT-L:

Pressing the "DOWN" pushbutton or foot switch will turn on the power unit to lower the platform. Releasing the control will stop the platform movement, and the unit will hold its position.

*Caution:* Never use the tilting table if any damage or unusual noise is observed, if it is in need of repairs, or if it seems to be malfunctioning. Notify your supervisor or maintenance personnel if you notice anything out of the ordinary.

Ensure that all safety and warning labels stay in place and are legible. Refer to the labels page in this manual.

## **ROUTINE MAINTENANCE & SAFETY CHECKS – EM1-200 & -500, EHTT, EHTT-L**

- *Warning: Care should be taken to identify all potential hazards and comply with applicable safety procedures before beginning work.*
- *Warning: The load must be removed, and the platform either positively and adequately supported or fully tilted, before any work is performed on the tilter.*
- *Only qualified individuals trained to understand mechanical devices and their associated electrical and hydraulic circuits should attempt troubleshooting and repair of this equipment*

(A) Before each use inspect for the following:

- 1.) Frayed wires
- 2.) Oil leaks
- 3.) Pinched or chafed hoses
- 4.) Damage or structural deformation to the structural members, the cylinder brackets, etc.
- 5.) Unusual noise or binding, or evidence thereof.
- 6.) Proper functioning of all limit switches.

(B) Inspect monthly for:

- 1.) The oil level. Oil should be within 1" of the reservoir's fill hole with the cylinder retracted. See below for the hydraulic oil specification.
- 2.) Worn or damaged hydraulic hoses and electrical wires.
- 3.) Hydraulic fluid leaks in any part of the hydraulic circuit.
- 4.) Pivot point wear.
- 5.) Rollers' looseness and wear. (EHTT-L only.)
- 6.) Integrity of the retaining hardware on all rollers and on all pivot point pins.
- 7.) The integrity of the frame anchor bolts, and for cracks in the concrete around them. (Non-portable units only.)
- 8.) Damage or evidence of fatiguing to the fork tubes. (Portable units only.)
- 9.) Evidence of fatigue (deformation of the structural parts, cracked welds, wrinkled paint). Check the entire machine, especially diligently at points that can receive shock-loading such as at hinge pivot areas and cylinder brackets.
- 10.) Unusual noises or movement during operation.
- 11.) All the information, safety, and warning labels being in place and in good condition.
- 12.) The need to clean off dirt and debris.
  - ◆ Grease the cylinder pins monthly with bearing grease.

(C) Yearly inspection

The oil should be changed if the oil darkens, becomes gritty, or turns a milky color (indicating the presence of water). Replace with an anti-wear hydraulic oil with a viscosity grade of 150 SUS at 100°F, (ISO 32 at 40°C). Ex: AW 32 or HO 150 hydraulic oil, or a non-synthetic transmission fluid. You may use a synthetic transmission fluid if you flush the system with the synthetic fluid before filling the reservoir.

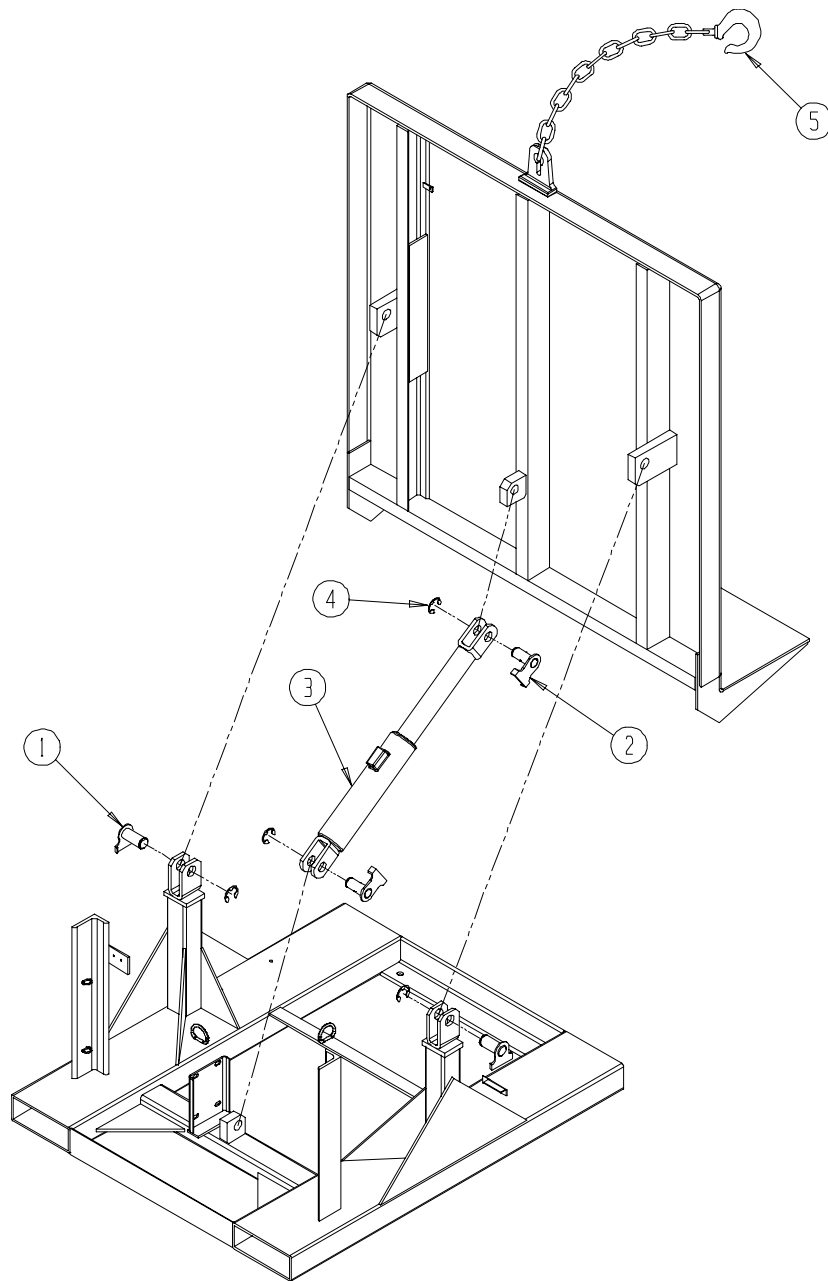
**EXPLODED PARTS VIEW -- EM1-200****BILL OF MATERIALS -- EM1-200**

<b>Item #:</b>	<b>Description</b>	<b>Part number</b>	<b>Qty.</b>
1	Pin assembly, hinge, 1 <sup>1</sup> / <sub>8</sub> "Ø	03-612-001	2
2	Pin assembly, cylinder, 1"Ø	03-612-002	2 or 4
3	Cylinder, 2" x 8"	99-021-919	1 or 2
4	Snap ring, 1" external	A/L	2 or 4
5	Chain, ¼" welded, and clevis slip hook, ¼"	A/L	1
6	Snap ring, 1 <sup>1</sup> / <sub>8</sub> " external (not shown)	A/L	2

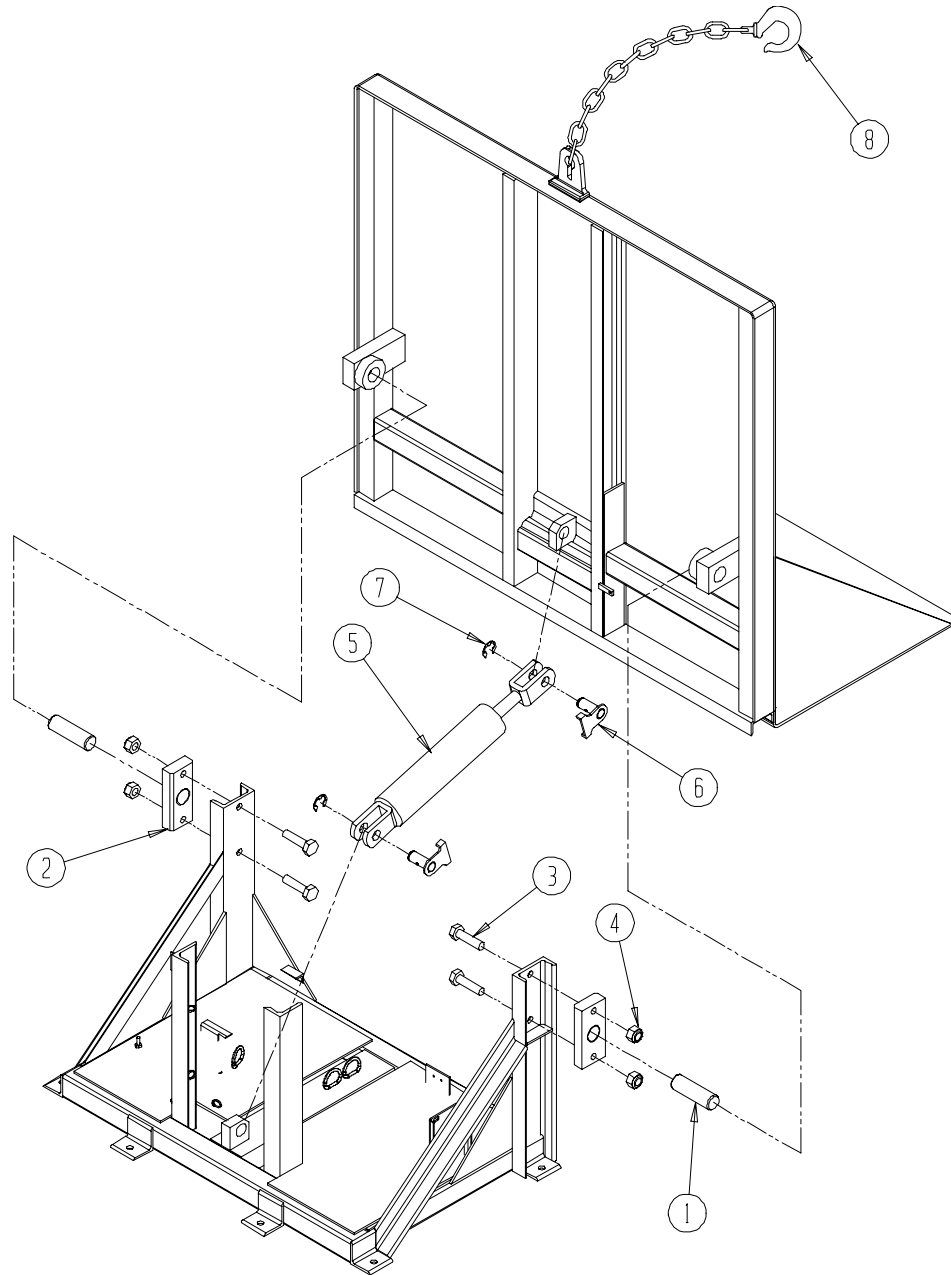
**EXPLODED PARTS VIEW -- EM1-500****BILL OF MATERIALS -- EM1-500**

Item #:	Description	Part number	Qty.
1	Pin, hinge block, 1 $\frac{1}{2}$ " $\varnothing$ x 4 $\frac{1}{8}$ " long	09-112-009	2
2	Pivot block, hinge	09-516-012	2
3	Bolt, $\frac{3}{4}$ "-10 UNC x 3" long, Grade 5	A/L	4
4	Nut, nylock, $\frac{3}{4}$ "-10 UNC	A/L	4
5	Cylinder, 3" x 12"	99-021-920	1 or 2
6	Pin assembly, cylinder, 1" $\varnothing$	03-612-002	2 or 4
7	Snap ring, 1" external	A/L	2 or 4
8	Chain, $\frac{1}{4}$ " welded, and clevis slip hook, $\frac{1}{4}$ "	A/L	1

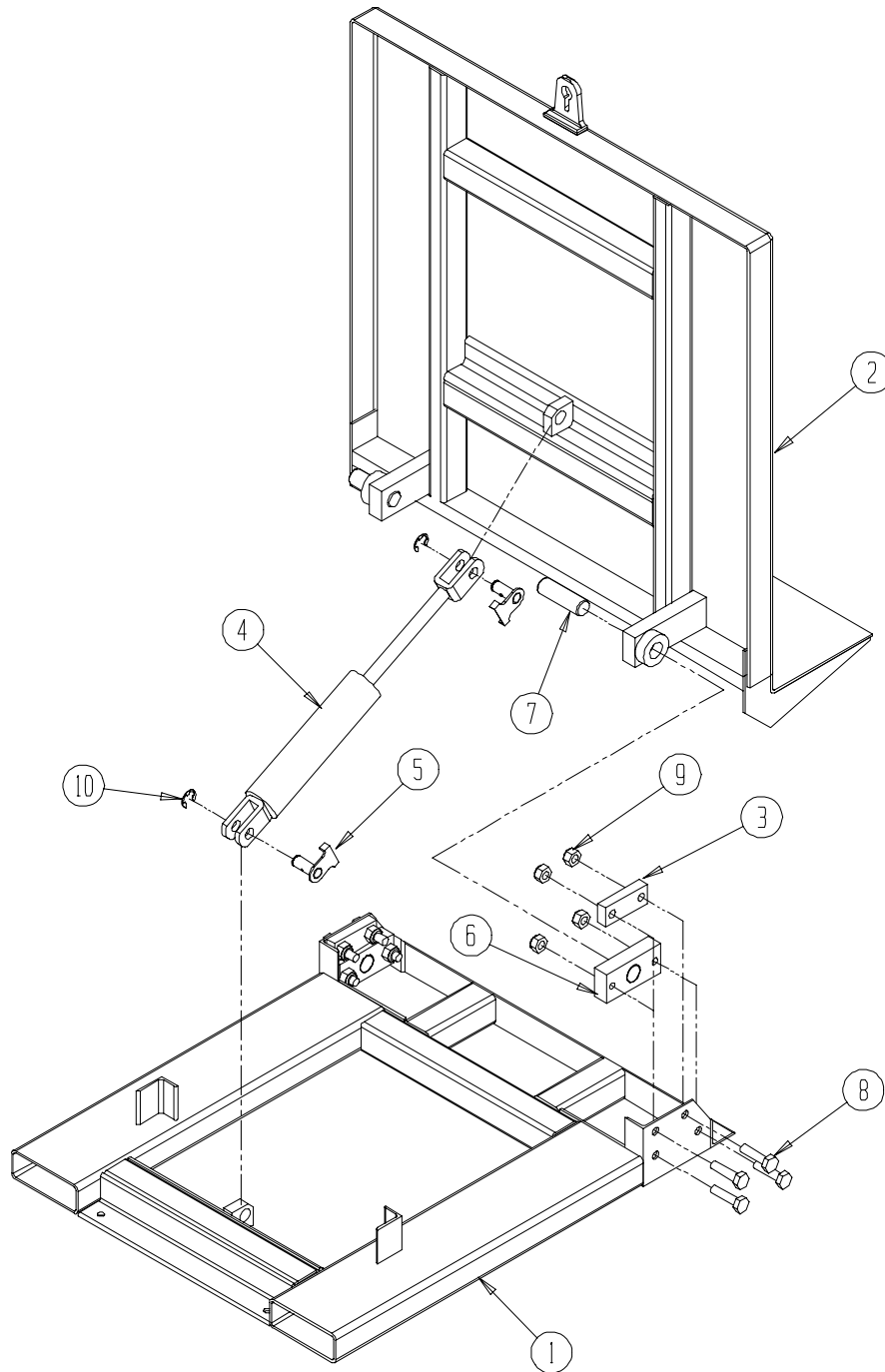
**EXPLODED PARTS VIEW -- EHTT****BILL OF MATERIALS -- EHTT**

Item #:	Description	Part number	Qty.
1	Weldment, base	38-514-009	1
2	Weldment, platform	38-513-003	1
3	Stop block, hinge	38-037-002	2
4	Cylinder, 3" x 10"	99-021-902	1 or 2
5	Pin, hinge assembly, 1"Ø	03-612-002	2
6	Pivot block, hinge	34-516-001	2
7	Pin, hinge block, 1 1/2"Ø x 4 1/8" long	09-112-009	2
8	Bolt, 3/4" -10 UNC x 3" long Grade 5	A/L	8
9	Nut, nylock, 3/4" -10 UNC	A/L	8
10	Snap ring, 1" external	A/L	2 or 4
11	Chain, 1/4" welded, and clevis slip hook, 1/4" (not shown)	A/L	1

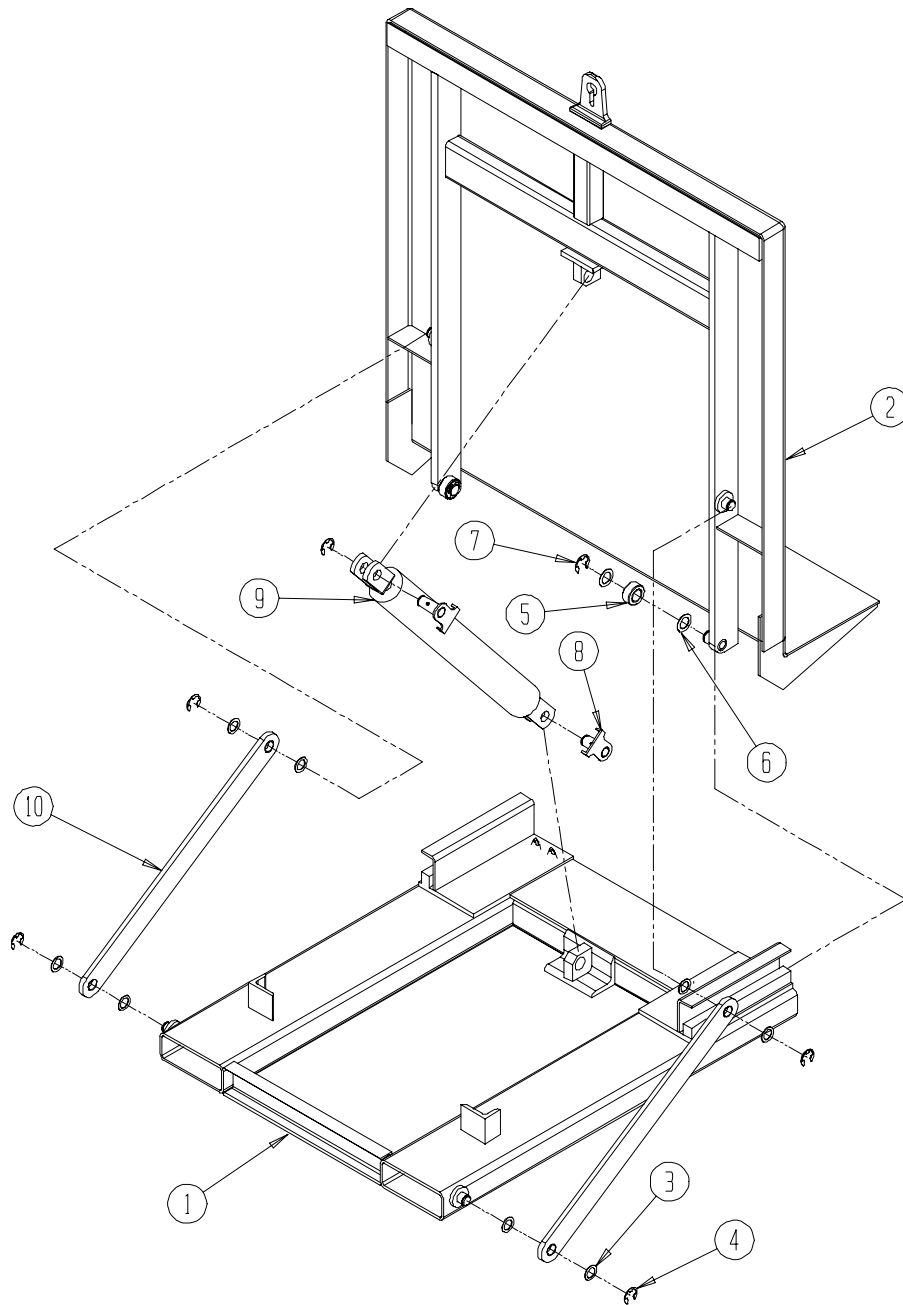
**EXPLODED PARTS VIEW -- EHTT-L****BILL OF MATERIALS -- EHTT-L**

Item #:	Description	Part number	Qty.
1	Weldment, frame	03-514-012	1
2	Weldment, deck	03-513-018	1
3	Bushing, machine, 1" ID x 18 gauge	A/L	8
4	Snap ring, 1" external	A/L	6
5	Roller, w/ 1 <sup>1</sup> / <sub>8</sub> " ID sleeve bearing; 2" OD x 1 <sup>1</sup> / <sub>8</sub> " long	02-527-002	2
6	Bushing, machine, 1 <sup>1</sup> / <sub>8</sub> " ID x 18 gauge	A/L	4
7	Snap ring, 1 <sup>1</sup> / <sub>8</sub> " external	A/L	2
8	Pin assembly, cylinder	03-612-002	2 or 4
9	Cylinder, 3" x 12"	99-021-920	1 or 2
10	Linkage	03-540-017	2
11	Chain, 1/4" welded, and clevis slip hook, 1/4" (not shown)	A/L	1



# MOTOR & TRANSFORMER CONNECTION DIAGRAMS

**CAUTION!** *If the motor voltage is changed, the wire on the control transformer's primary wire has to be changed to match the new motor voltage also.*

MOTOR LEAD CONNECTION DIAGRAM FOR ALL  
.5HP, .75HP AND 3HP SINGLE-PHASE MOTORS AND FOR  
ALL 2HP, 5.5HP, AND 6.5HP THREE-PHASE MOTORS

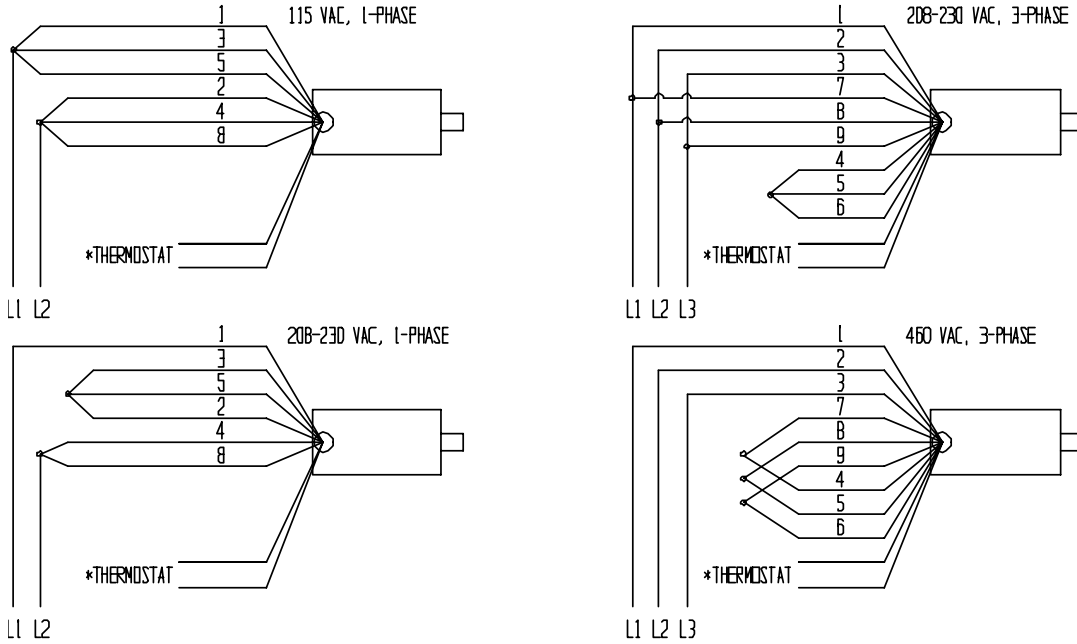

\* The two thermostat leads go to: 1) the grounded side of the transformer secondary, and; 2) the motor relay coil, in either order.

**⚡ BE SURE ALL POWER IS OFF BEFORE ATTEMPTING TO WORK ON THIS EQUIPMENT!**  
**CAUTION: SERVICE WORK SHOULD BE PERFORMED ONLY BY TRAINED & QUALIFIED PERSONNEL.**

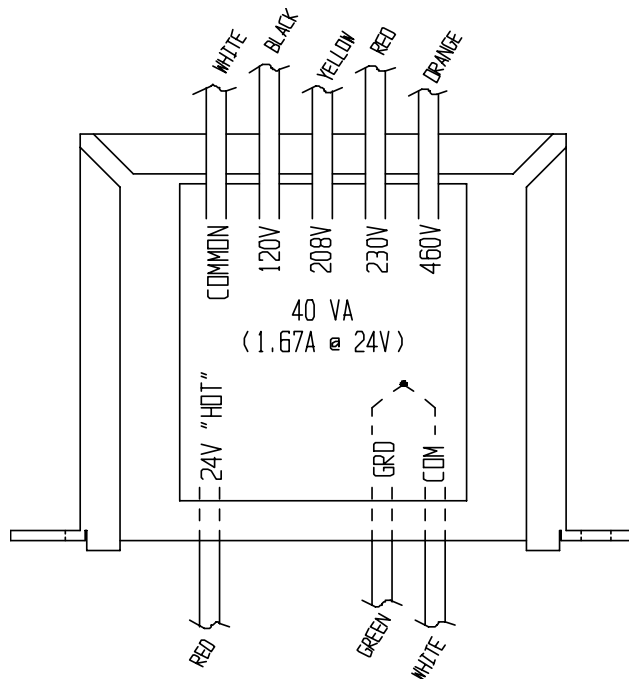

# ELECTRICAL DIAGRAMS -- EM1-200 & -500, EHTT, EHTT-L

- o Warning: Care should be taken to identify all potential hazards and comply with applicable safety procedures before beginning work. Ensure that all system pressure and power have been removed before attempting to work on the electrical or hydraulic systems.
- o *Warning:* The load must be removed, and the platform either positively and adequately supported or fully tilted, before any work is performed on the tilter.
- o *Only qualified individuals trained to understand mechanical devices and their associated electrical and hydraulic circuits should attempt troubleshooting and repair of this equipment.*

Note: The platform is "raising" when the platform to which the cylinder is attached is moving to the level position. On standard units, the cylinder will extend when the "UP" control is pressed.

OVERCURRENT & SHORT-CIRCUIT PROTECTION, AND DISCONNECT ARE TO BE PROVIDED BY THE END-USER PER THE NEC (NFPA 70) AND LOCAL CODES.

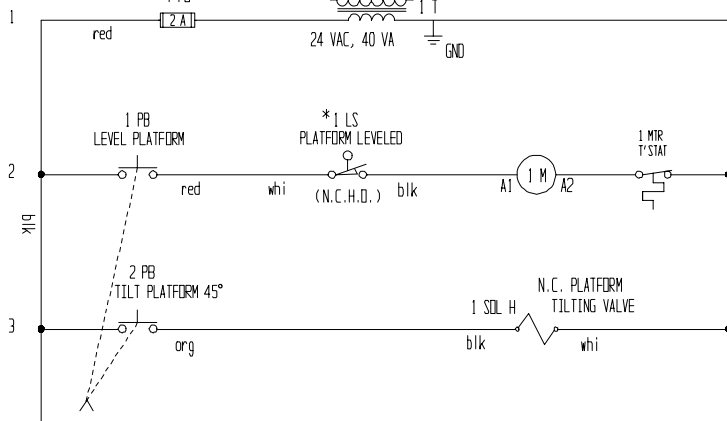
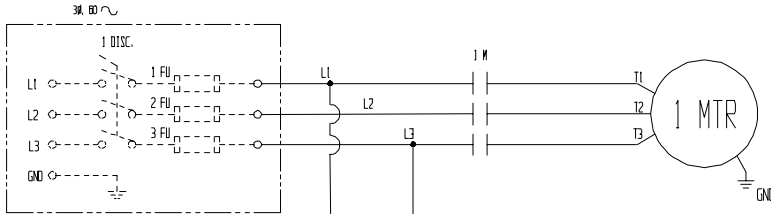

**Model EM1-200**

NOTES:

----- Indicates wire and/or components supplied by others

\* ALL COMPONENTS ARE REPRESENTED AS THEY WOULD BE WITH THE TABLE IN ITS "HOME", OR RESTING, POSITION. WHEN THE PLATFORM THAT HAS CYLINDER(S) ATTACHED TO IT IS HORIZONTAL, THE TABLE IS IN THE HOME POSITION.

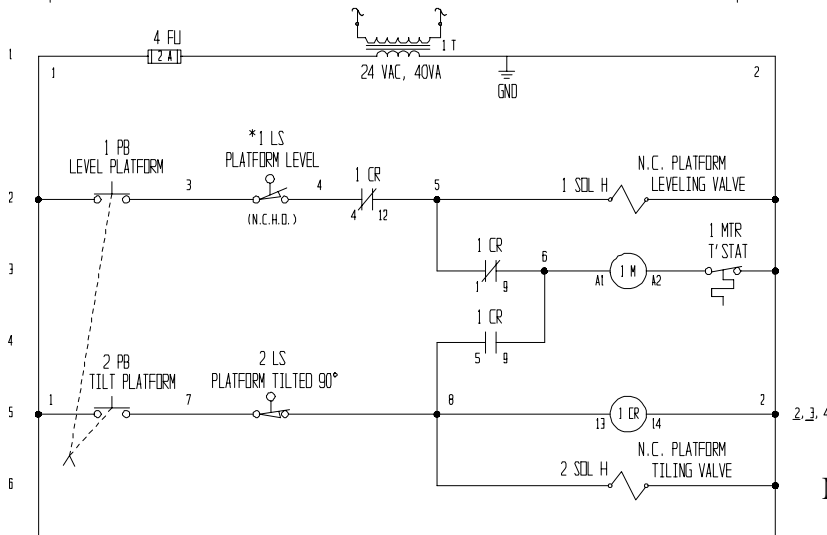

**RELAY BASE (TOP VIEW) LAYOUT**

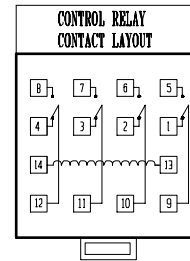

**Models EM1-500, EHTT, EHTT-L**

**⚡ BE SURE ALL POWER IS OFF BEFORE ATTEMPTING TO WORK ON THIS EQUIPMENT!**  
 CAUTION: SERVICE WORK SHOULD BE PERFORMED ONLY BY TRAINED & QUALIFIED PERSONNEL

### HYDRAULIC DIAGRAM – LIFT-HOLD-LOWER CIRCUITS

- *Warning: Care should be taken to identify all potential hazards and comply with applicable safety procedures before beginning work. Ensure that all system pressure and power have been removed before attempting to work on the electrical or hydraulic systems.*
- *Warning: The load must be removed, and the platform either positively and adequately supported or fully tilted, before any work is performed on the tilter.*
- *Only qualified individuals trained to understand mechanical devices and their associated electrical and hydraulic circuits should attempt troubleshooting and repair of this equipment.*
  - *Caution: Do not use brake fluid or jack oils in the hydraulic system. If oil is needed, use an anti-wear hydraulic oil with a viscosity of 150 SUS at 100°F (ISO 32 @ 40°C), or non-synthetic transmission fluid.*

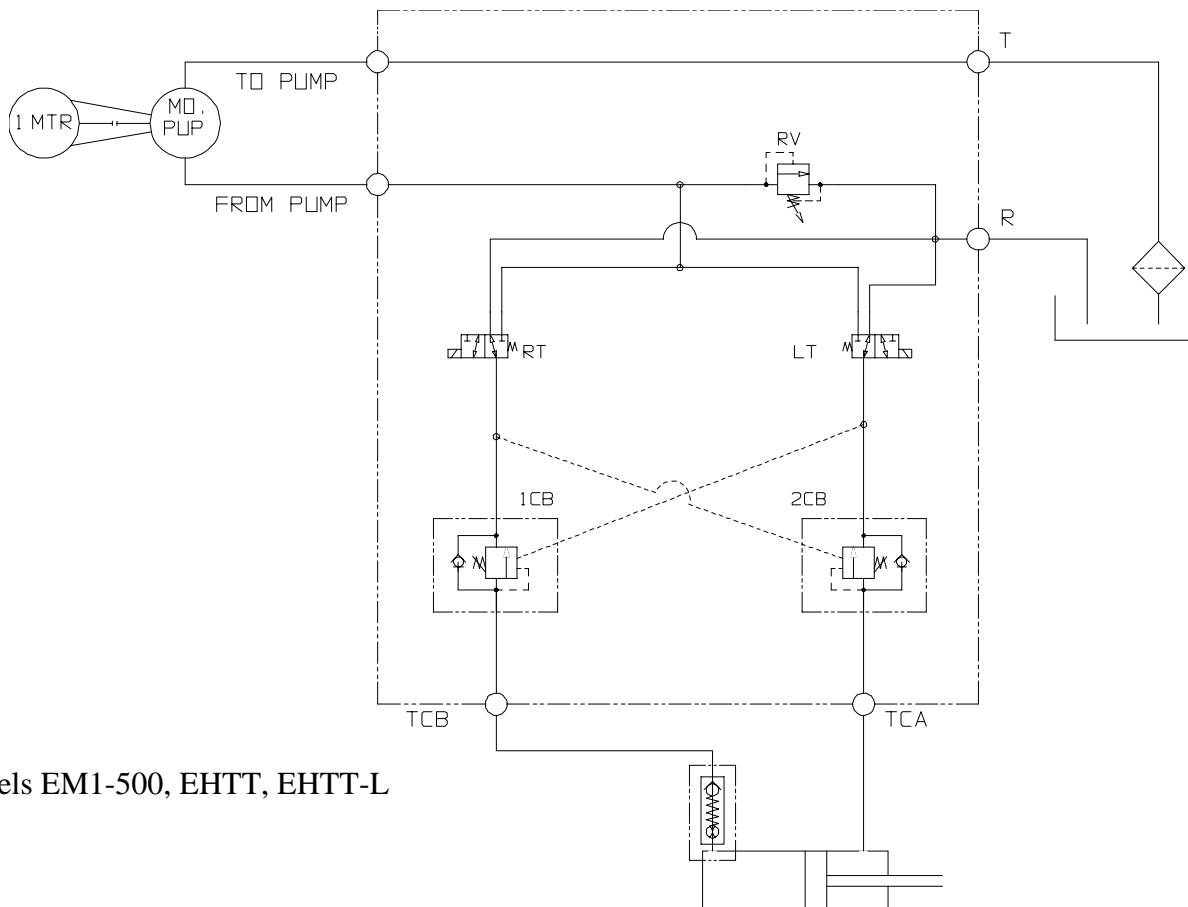
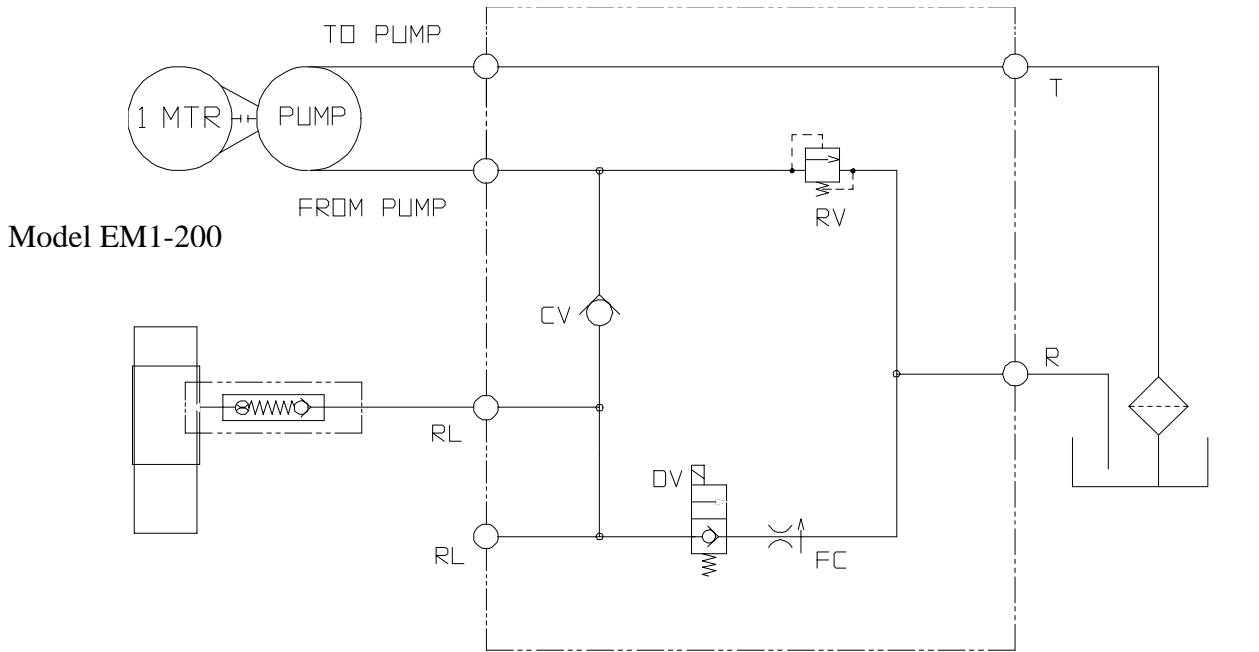

**ELECTRIC / HYDRAULIC BOM – EM1-200 & -500, EHTT, EHTT-L**

Item #:	Qty.:	Part number:	Part description:
		Electrical parts:	
1	1	01-135-XXX	Motor; varies by customer spec; contact factory
2	1	LC1-D1810-24V	Motor contactor, 30A, w/ 24 VAC coil
3	1	01-129-001	Transformer, control; w/ 24 VAC secondary
4	1	AGC 2	Fuse, for control circuit
5	1	01-029-006	Control enclosure, 6"W x 6"L x 4"D (EM1-200)
	1	01-029-007	Control enclosure, 6"W x 8"L x 4"D (EM1-500, EHTT, EHTT-L)
6	1	01-522-015	Pushbutton control on 8' cord
7	1 or 2	99-034-008	Solenoid coil, 24 VAC (2 on EM1-500, EHTT, EHTT-L)
8	1 or 2	01-033-017	Connector cord, for solenoid (2 on EM1-500, EHTT, EHTT-L)
9	1	01-033-015	Cord, power, 14/3, 9' long, w/ NEMA 5-15 plug (115V units)
10	1 or 2	01-022-001	Limit switch, roller-arm (N.C.) (2 on EM1-500, EHTT, -L)
11	1	159/D	Multi-pole terminal strip
		Hydraulic parts:	
12	1	99-153-006	Valve, relief, 210 bar
13	1	99-153-015	Valve, solenoid, N.C. (EM1-200)
14	2	99-153-017	Valve, 2-pos, 3-way (EM1-500, EHTT, EHTT-L)
15	2	99-153-019	Valve, 3:1 counterbalance (EM1-500, EHTT, EHTT-L)
16	1	99-153-011	Valve, check
17	1	99-153-038	Flow control spool, 1 gpm (EM1-200)
18	1 or 2	99-021-XXX	Cylinder, displacement; varies by model and size; contact factory
19	1 or 2	99-136-XXX	Cylinder seal kit; contact factory
20	1	01-127-010B	Manifold, single-acting (EM1-200)
	1	99-127-016B	Manifold, double-acting (EM1-500, EHTT, EHTT-L)
21	1	01-143-XXX	Pump, hydraulic; varies by model; contact factory
22	1	01-123-008	Reservoir (EM1-200)
	1	03-023-001	Reservoir (EM1-500, EHTT, EHTT-L)
23	1	DPS-40-N06	Breather plug
24	1	01-031-005	Fitting, intake screen (EM1-500, EHTT, EHTT-L)
25	3-5	HO 150	Hydraulic fluid (quarts)

## THE POWER UNIT'S OPERATION -- EM1-200 & -500, EHTT, EHTT-L

The electric / hydraulic tilting tables utilize an electric motor directly coupled to a gear-type hydraulic pump to produce the needed fluid pressure and flow to allow the cylinders to perform the work of tilting a container or pallet.

A hydraulic manifold houses the hydraulic control components, and is bolted directly onto the gear pump.

The power unit's hydraulic components are all rated for 3,000 psi working pressure.

- 👉 Important parts of the power unit include:
  - ◆ The electric motor. Motors are available for operation on single- or three-phase AC supplies (all are dual-voltage capable).
  - ◆ The gear pump. Its shaft is coupled directly to the shaft of the electric motor. Several displacements are available, depending on the motor horsepower used.
  - ◆ The check valve. Its purpose is to prevent the backflow of fluid through the pump. In this way it allows the platform to be held at a given elevation indefinitely.
  - ◆ The pressure relief valve. Its job is to open a path for fluid to flow back to the reservoir in the event that the fluid pressure built up by the pump exceeds 3,000 psi. Thus the system cannot see more than 3,000 psi.
  - ◆ The lowering solenoid valve (EM1-200 only). This is an electrically-operated cartridge valve. It contains a screen to keep contaminants from entering the valve.
  - ◆ The 3-way, 2-position valves (EM1-500, EHTT, EHTT-L). These valves control the direction of oil flow in double-acting circuits.
  - ◆ The counterbalance valves (EM1-500, EHTT, EHTT-L). These valves allow for smooth motion in double-acting circuits.
  - ◆ The pressure-compensated flow control spool (EM1-200 only). This regulates the fluid flow back to the reservoir when the valve opens. It allows the platform to always lower at the same rate regardless of whether there is a load on the platform or not. Several sizes are available.
  - ◆ The hydraulic cylinder(s). See the note below to bleed air from the cylinder.
  - ◆ The safety velocity fuse. This is a device that is installed in the cylinder's blind-end hose port. It closes quickly in the event of a catastrophic hose failure to prevent the platform from collapsing down. The platform will remain stationary until pressure is reapplied to the system.
  - ◆ The hydraulic fluid. The system uses HO150 hydraulic fluid. Any anti-wear hydraulic fluid with a viscosity grade of 150 SUS at 100°F (ISO 32 @ 40°C) such as AW-32 or Dexron transmission fluid are acceptable.
    - When the platform is to be leveled (the backstop raised), press the "RAISE" pushbutton. The motor turns, and in turning it spins the hydraulic gear pump. Oil is drawn from the reservoir through the suction filter and into the pump.
      - For the EM1-200:
        - The pump pushes the pressurized oil through the check valve and out to the cylinder(s). Releasing the pushbutton at any point will stop the motion, and the platform will hold at that angle. An upper travel limit switch turns off the motor when the platform is at its maximum tilt angle.
          - For the EM1-500, the EHTT, and the EHTT-L:
            - The pump pushes the pressurized oil through an actuated directional valve, then through a counterbalance valve, and out to the blind end of the cylinder(s). Oil is pushed out of the rod end of the cylinder, through a counterbalance valve and the non-actuated directional valve (it stays in its default position), and back to the reservoir.
              - When the platform is to be tilted (the backstop lowered), press the "LOWER" pushbutton.
                - For the EM1-200:
                  - The lowering valve opens, bypassing the check valve and allowing the oil in the cylinder to return back to the reservoir through the return hose. The rate at which the platform lowers is regulated by the internal pressure-compensated flow spool. Releasing the pushbutton at any point will stop the motion, and the platform will hold at that angle.
                    - For the EM1-500, the EHTT, and the EHTT-L:
                      - The pump pushes the pressurized oil through an actuated directional valve, through a counterbalance valve, and out to the rod end of the cylinder(s). Oil is pushed out of the blind end of the cylinder, through a counterbalance valve and the non-actuated directional valve (in its default position), and back to the reservoir.
  - 👉 In the event that the platform creeps down slowly after releasing a "LOWER" control, it will be necessary to remove the lowering cartridge valve for inspection and cleaning, as follows:
    - Remove any load from the platform.
    - Fully tilt or adequately support the platform so that it is safe to work underneath. (Comply with OSHA regulations.)
    - Remove the nut holding the solenoid coil on the valve stem, then remove the coil, then unscrew the valve from the manifold.
    - Inspect the valve for contaminants, and the valve's o-rings and back-up washers for cuts, tears, or other damage.
    - With the valve immersed in mineral spirits or kerosene, use a thin tool such as a small screwdriver or a small hex wrench to push the poppet in and out several times from the bottom end of the valve. The valve should move freely, about 1/16" from closed to open position. If it sticks in, the valve stem could be bent and will need to be replaced if it doesn't free up after cleaning. Blow the valve off with a compressed-air gun while again pushing the poppet in and out.
    - Inspect the bottom of the manifold's valve cavity for contaminants.
    - Reinstall the valve into the manifold, tightening the valve with approximately 20 lb-ft of torque.
  - 👉 If the platform lowers extremely slowly, or not at all, the cylinder's velocity fuse could be closing. This can be caused by air in the hydraulic cylinder. To bleed the air from the system:
    - Remove any load from the platform. This will reduce the fluid pressure in the cylinder(s), and the velocity fuse(s) will open.
    - Fully tilt or adequately support the platform so that it is safe to work underneath. (Comply with OSHA regulations.)
    - Unpin and drop the higher end of the cylinder(s) down. Hold a rag over the cylinder's blind-end hose fitting and loosen the fitting about ½ turn. Push the cylinder rod in. Oil and air will sputter from the fitting - once no air is observed, tighten the hose fitting and reattach the rod end of the cylinder to the platform.

## TROUBLESHOOTING GUIDE -- EM1-200 & -500, EHTT, EHTT-L

- o *Warning:* The load must be removed, and the platform either positively and adequately supported or fully tilted, before any work is performed on the tilter.

*Consult the factory for problems at time of installation, or for any problems not addressed below.*

| <u>Problem:</u>  | <u>Possible cause(s):</u>   | <u>Action:</u>   |
|--|---|--|
| Power unit doesn't run when "UP" button is pressed.  | Transformer fuse is blown.<br>No supply voltage.  | Test with meter; replace if bad.<br>Test with meter. Check fuses, breakers, and overloads to determine the cause.  |
|  | Limit switch is engaged or bad.   | Inspect and test switch. Replace if bad.   |
|  | Bad connection in control circuit.<br>Bad control transformer.<br>Open motor relay coil.  | Test all parts of circuit with meter.<br>Check for 24 VAC; replace if bad.   |
| Motor runs properly, platform doesn't move. Motor and pump not noisy.  | Motor rotation is wrong.<br>Pump has failed.<br>Fluid level is low.   | Test with meter; replace if bad.<br>Verify motor shaft rotates CCW.<br>Consult factory for replacement.<br>Ensure reservoir is filled to within 1" of the fill hole.   |
| Motor or control enclosure hums, chatters, or buzzes, or some type of squeal can be heard; the platform does not move, or the platform moves only slowly.. | See second item above, for when platform doesn't raise.<br>Excess voltage drop to motor, due to power wire size too small, wire run to long, or incoming voltage too low.<br>Motor is "single-phasing" (three-phase units only).<br>Pressure relief opening at full pressure. | Same as above.<br>Check power installation for adequacy. Check incoming voltage <i>while motor is running</i> .<br>Correct problem found.<br>Determine cause of loss of voltage on one phase; correct.<br>Check for structural damage.<br>Check for platform overload condition. |
| Platform backstop drifts down.   | (EM1-200 only.) Contamination holding open the lowering valve or the check valve.<br>(EM1-500, EHTT, EHTT-L only.) Counterbalance valve setting is incorrect.   | Remove and inspect. Clean per instructions in this manual.<br>Increase the setting for counterbalance valve "1CB" (turn the socket-head screw CW).   |
| Platform tilts down too quickly.   | (EM1-200 only.) Flow control spool is stuck.  | See below.   |
| Platform tilts down too slowly.  | (EM1-200 only.) Flow control spool is stuck.<br><br>Pinched hose.   | Remove plug from FC port; push on flow spool to ensure it is fully pressed into the cavity.<br>Check pressure, supply, and return hoses for kinks.<br>Same as for jerky platform motion.   |
|  | Velocity fuse locking (platform only very slowly creeps down).<br>(EM1-500, EHTT, EHTT-L only.) Counterbalance valve setting is incorrect.  | Decrease the setting for counterbalance valve "1CB" (turn the socket-head screw CCW).  |
| Platform won't tilt down.  | Velocity fuse locking.<br>Control transformer fuse blown.<br>No supply voltage.<br><br>Valve solenoid is bad.   | Same as for jerky platform motion.<br>Test with meter; replace if bad.<br>Test with meter. Check for cause of power loss.<br>Check solenoid with multimeter on diode-check function. (Reading for ohms will not provide an accurate test of the coil.)                           |
|  | Bad connection in control circuit.<br>Physical blockage of the structure.   | Test all parts of circuit with meter.<br>Inspect for foreign material or objects that might block the platform.  |
|  | Solenoid valve or suction hose screen plugged.  | Remove and inspect. Clean per instructions in this manual.   |
| Spongy or jerky platform motion.   | Excessive air in the hydraulic cylinders.<br>(EM1-500, EHTT, EHTT-L.) Counterbalance valve(s) setting is incorrect.   | Bleed air per procedure described in this manual.<br>Consult the factory.  |

# SAFETY LABEL IDENTIFICATION -- EM1-200 & -500, EHTT, EHTT-L

\* Product safety signs or labels should be periodically inspected and cleaned by the product users as necessary to maintain good legibility for safe viewing distance -- ANSI 535.4 (10.21). Contact the manufacturer for replacement labels.

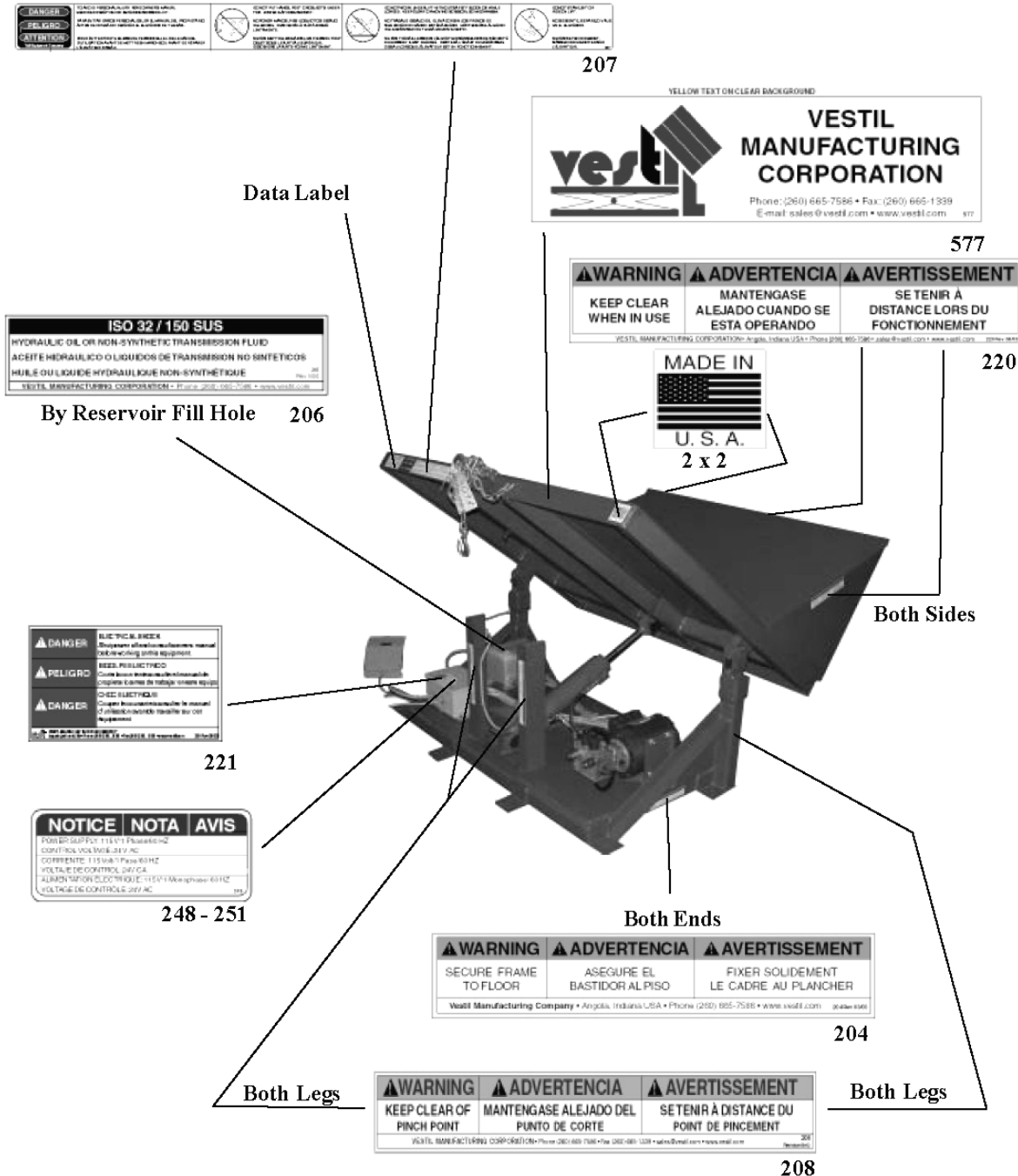

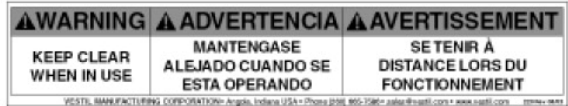

By Reservoir Fill Hole

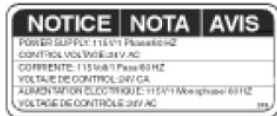

Data Label

Both Sides

Alternate Corners

Both Sides



# **POWERED PRODUCTS' WARRANTY**

## **ONE YEAR LIMITED WARRANTY**

The manufacturer warrants for the original purchaser against defects in materials and workmanship under normal use one year after date of shipment (not to exceed 15 months after date of manufacture). Any part that is determined by the manufacturer to be defective in material or workmanship and returned to the factory, shipping costs prepaid, will be, as the exclusive remedy, repaired or replaced at our option. Labor costs for warranty repairs and/or modifications are not covered unless done at manufacturer's facilities or pre-approved in advance by the manufacturer. Any modifications performed without written approval of the manufacturer may void warranty. This limited warranty gives purchaser specific legal rights which vary from state to state.

All specifications are subject to change without notice.

## **LIMITATION OF LIABILITY**

To the extent allowable under applicable law, the manufacturer's liability for consequential and incidental damages is expressly disclaimed. The manufacturer's liability in any event is limited to, and shall not exceed, the purchase price paid. Misuse or modification may void warranty.

Warranty does not cover labor or consequential damages including, but not limited to, business interruption costs, lost profits, or lost business opportunities.

## **WARRANTY DISCLAIMER**

The manufacturer has made a diligent effort to accurately illustrate and describe their products. However, such illustrations and descriptions are for the sole purpose of identification, and do not express or imply a warranty that the products are merchantable or fit for a particular purpose, or that the products will necessarily conform to the illustrations or descriptions.

The provisions of the warranty shall be construed and enforced in accordance with the Uniform Commercial Code and laws as enacted in the State of Indiana.

## **DISPOSITION**

Our company will make a good faith effort for prompt correction or other adjustment with respect to any product that proves to be defective within the Limited Warranty Period. Warranty claims must be made in writing within said year.

**NOTES:**